

981-10 and 982-10 Easiprox Split (separate controller and reader) Stand-Alone Proximity Access Control System

GENERAL DESCRIPTION

The "Easiprox Split" system is a low cost stand-alone programmable access control system based on the EM400x proximity tags and cards. The system consists of two units: a controller (981-10) and a separate read head (982-10). The memory and relay circuitry are located on the controller board which can be installed in a secure location up to 50m away. The read head is rated IP67 and can be installed in an outdoors location. The system can store the codes of 2000 unique tags. Adding and deleting tags is done by simple use of a Master Tag. The optional Tag Simulator / Programming Unit allows the programming (adding & deleting) of lost tags. The Relay can operate in Pulse or Toggle mode.

Normal Operation (Run State)

The Easiprox has two states, Programming and Run. The Run state is the normal operating state of the Easiprox. The LEDs behave as follows depending on the Relay mode - Pulse or Toggle. The Programming state is explained in the next section.

Run State - Pulse Mode

In this state, the YELLOW lamp is always on and the GREEN/RED lamp is off. Whenever a valid tag is read, the GREEN lamp will go on and the relay will operate, for the pre-set Relay Pulse time. If a card is not recognized the RED lamp will go on for 1.5 seconds.

Run State - Toggle Mode

On power-up, the YELLOW and RED lamps will be on and the relay will be off. Whenever a valid tag is read the GREEN/RED lamp will change state. When the lamp is GREEN, the relay is energized (the NO contact will be closed). When the lamp is RED, the relay is not energized (the NO contact will be open).

Programming

The Master Tag is the first tag presented to the Easiprox when it is in the Add Master state. All programming is done by using this Master Tag. To select a program function: Make successive reads of the Master Tag (each read must be no more than 2 seconds apart). Each read of the Master Tag sets the Easiprox to a new programming function. Once the required function has been reached, wait for the lamp(s) to start flashing, (approximately 3 seconds), indicating that the Easiprox is now in the selected function.

Add Master Tag

If the GREEN and YELLOW lamps are flashing, it indicates that the memory is empty and that there is no Master Tag. In this state the first tag read will be stored as the Master Tag.

Add Tags

To select this function:

Read the Master Tag once. → Only the GREEN lamp will light. → Wait for the GREEN lamp to start flashing.

The Easiprox is now in the ADD state.

In this state every tag that is presented to the reader will be stored in the system memory. (Tags can now also be added by using the optional Tag Simulator.) If a large number of tags have to be added, the ADD-ON-THE-RUN method can be used by leaving the Easiprox in the Add Tags state. In this state every tag presented to the Easiprox will operate the relay and be

added to memory. Once all the required tags have been presented, read the Master Tag to return to the RUN state.

Delete Tags

To remove a tag from the system, that tag must be available or the Tag Simulator must be used. If these are not available, the system memory must be cleared and all valid tags re-added.

To select this function:

Read the Master Tag twice with a time between reads of less than 2 seconds. → The RED lamp will light. → Wait for the RED lamp to start flashing.

The Easiprox is now in the DELETE state. In this state every tag that is presented to the reader will be deleted from the system memory. (Tags can now also be deleted by using the optional Tag Simulator.) Once the tag or a group of tags have been deleted, read the Master Tag to return to the RUN state.

Clear Memory

To delete all the tags from the memory including the Master Tag and Strike time, place the unit in the CLEAR MEMORY state.

Read the Master Tag three times with a time between reads of less than 2 seconds. → The YELLOW and RED lamps will light. → Wait for the YELLOW and RED lamps to start flashing.

The Easiprox is now in the CLEAR MEMORY state. Now present any tag except the Master Tag to the reader and all memory will be cleared. Alternatively, read the Master Tag to abort this function. Once the memory is cleared the YELLOW and GREEN lamps will flash to indicate that the memory is empty.

Time Adjust

This function sets the relay operating time for a push-button input and a valid card read.

To select this function:

Read the Master Tag 4 times with a time between reads of less than 2 seconds. → All the lamps will go off. → Wait for the YELLOW lamp to start flashing.

The Easiprox is now in the TIME ADJUST state and each flash of the YELLOW lamp equates to 1 second of relay operation time. Once the desired time is reached (max 60 seconds), read the Master Tag to store the time and return to the Run state. If TOGGLE mode is required simply allow the YELLOW lamp to flash until it stops automatically (after 61 flashes). The unit will now be in TOGGLE mode.

INSTALLATION

POWER

Connect 8-12V AC or 10-14V DC to the 12V AC/DC terminals on the controller. The polarity of the connection is not important.

ELECTRIFIED DOOR LOCK

The unit provides a relay output rated at 24 VDC at 3A . The following contacts, that are isolated from the rest of the board, are provided; normally open (NO) contact, normally closed (NC) contact and a common (COM). Typical connections to a door strike are shown on the drawing.

READHEAD

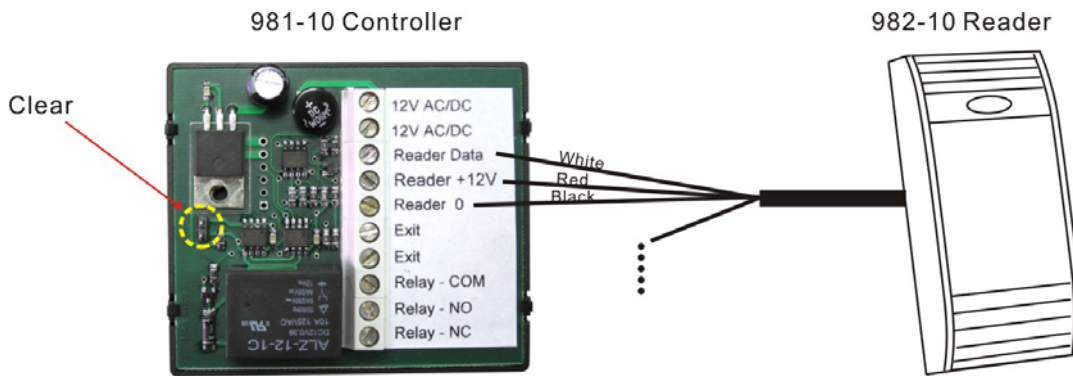

981-10 Controller(For AC Door Strike)

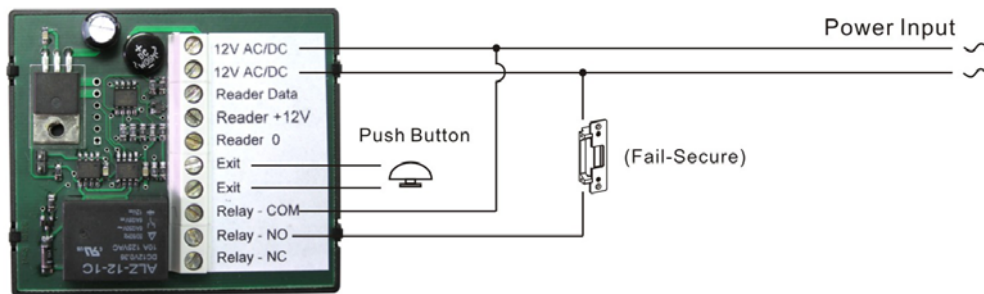

981-10 Controller(For DC Door Strike)

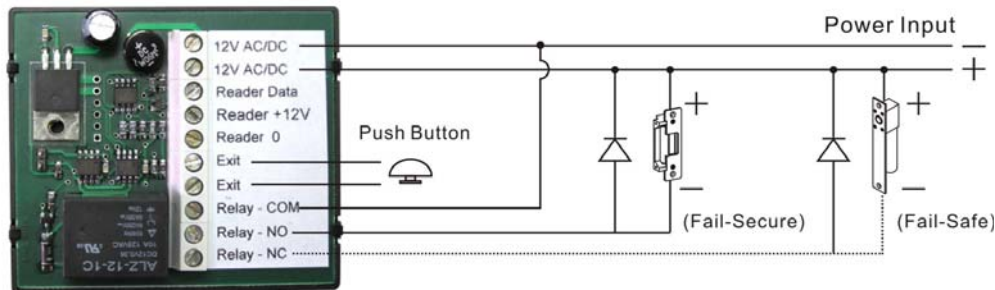

Note

When using a strike with DC, the relay contacts will be damaged by arcing due to back EMF when the contact opens. Use a IN4001 diode as shown on the drawing to prevent this damage.

Push-button

A push-button may be connected to allow remote operation of the door strike relay in the same manner as if a tag is read. The push button must be normally open and is wired between the two **Exit** terminals.

Warning: *The installer should earth himself before making contact with the controller board to avoid electrostatic discharge into the unit.*

Position

The Easiprox read head works on the principle of radiating a magnetic field from a coil. The field generated by the coil will be affected by the close proximity of metal. Ideally the Easiprox

read head should be mounted on non-metallic materials. If the unit is mounted on a metal surface the reading distance will be reduced. (Approx. 70 %)

Multiple read heads

The radiated field of the Easiprox coil extends in all directions including through brick walls. The coil of one Easiprox will interfere with another if they are mounted within 400mm of each other.

Clear SYSTEM Memory

To clear the system memory:

Remove power from the controller. → Reconnect power to the controller. → Short the CLEAR pins momentarily. This must be done before 5 seconds have elapsed since power up. See drawing on page 3 for position of CLEAR pins. → The LEDs on the read head will flicker during the memory clear operation. → When GREEN and YELLOW lamps are flashing, it indicates that the memory is empty and that there is no Master Tag. In this state the first tag read will be stored as the Master Tag.

Warning

The installer should earth himself before shorting the CLEAR jumper to avoid electrostatic discharge into the unit.

Pulse/Toggle Mode

The Easiprox relay can operate in 2 modes:

Pulse Mode

This mode is selected by selecting a pulse time 1-60 seconds. See Time Adjust programming function.

Toggle Mode

This mode is selected by selecting a pulse time >60 seconds. See Time Adjust programming function.

Deleting Tags

The MASTER tag must be used to put the 980-20 into the Delete mode.

Once in Delete mode:

RED lamp flashes. → Place the Tag Simulator close to the reader. → Hold down the On/Off button and check the displayed number. → Press the Send button. → The GREEN lamp will flash to verify that the selected number is deleted and then the RED lamp will continue flashing. → Once the tag or a group of tags have been deleted, read the Master Tag to return to the RUN state.

Adding Tags

The MASTER tag must be used to put the 980-20 into the Add mode.

Once in Add mode:

GREEN lamp flashes → Place the Tag Simulator close to the reader → Hold down the On/Off button and check the displayed number → Press the Send button → The GREEN lamp will go steady and the relay will operate to verify that the selected number is added. The GREEN lamp will then continue flashing. → Once the tag or a group of tags have been added, read the Master Tag to return to the RUN state.